

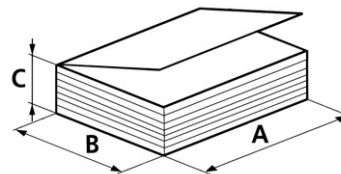

Book Counter Stacker CB-16

Specifications

Mechanical speed	maximum 18,000 copies per hour (depending on book thickness)	
	CB-16/240	CB-16/300
Infeed height adjustable	from 800 to 890 mm (31½" – 35")	from 800 to 890 mm (31½" – 35")
Horizontal infeed (optional)	1305 mm (51¾")	1395 mm (55¾")
Pre-stacking bin height	60 mm (2¾")	60 mm (2¾")
Intermediate stack height	120 mm (4¾")	150 mm (5¾")
Final stack height	240 mm (9½")	300 mm (11¾")
Delivery height	850 mm (33½")	850 mm (33½")



Sizes		A	B	C
Sizes, with belt delivery right/left	maximum	450 mm (17¾")	340 mm (13¾")	70 mm (2¾")
	minimum	140 mm (5½")	100 mm (4")	3 mm (⅛")
In travel direction	maximum	340 mm (13¾")	340 mm (13¾")	70 mm (2¾")
	minimum	140 mm (5½")	140 mm (5½")	3 mm (⅛")
Small size kit (optional)	minimum	120 mm (4¾")	100 mm (4")	3 mm (⅛")
Sizes, with roller delivery right/left	maximum	450 mm (17¾")	340 mm (13¾")	70 mm (2¾")
	minimum	140 mm (5½")	100 mm (4")	3 mm (⅛")
Power requirements	using one or two			
	delivery belts	1,35 kW		
	with roller delivery	1,1 kW		
Air requirements	50 Nm ³ /h (29 cfm), 6 bar (87 psi)			
Weight	approx. 1000 kg (2200 lbs)			

Front view

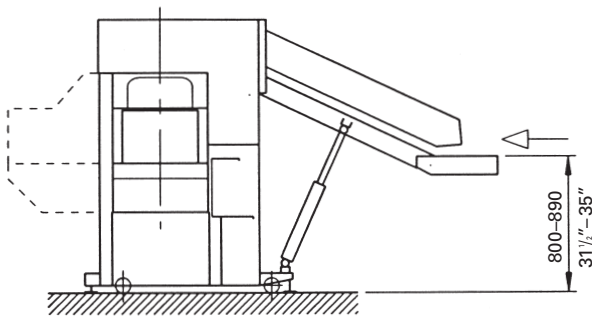

Side view (belt delivery)

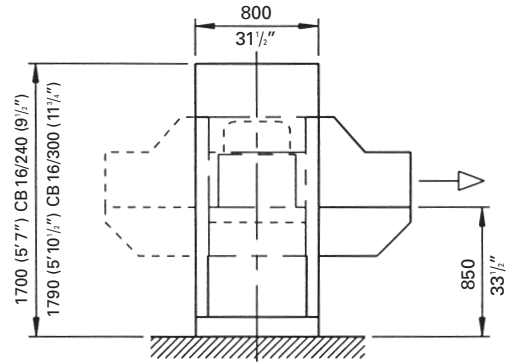

Top view (belt delivery)

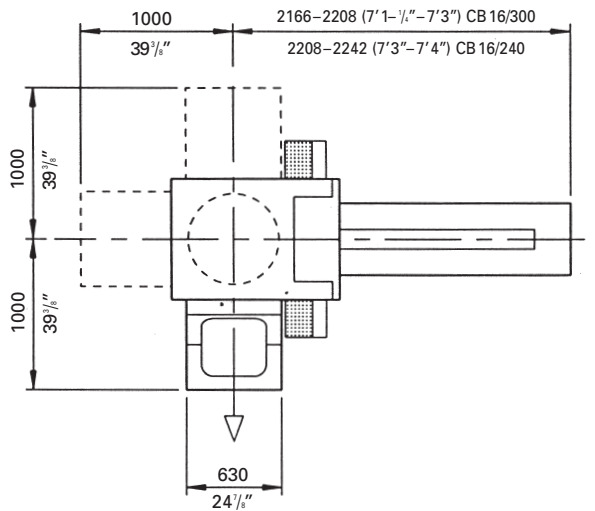

Side view (roller delivery) only for CB 16/240

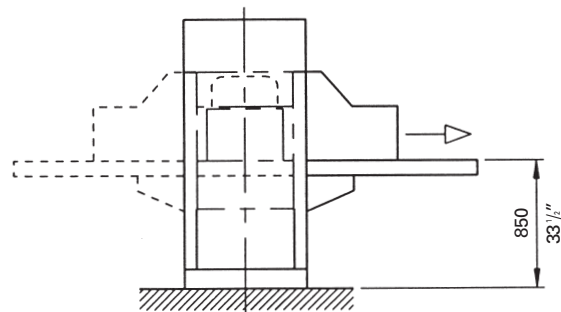

Top view (roller delivery) only for CB 16/240

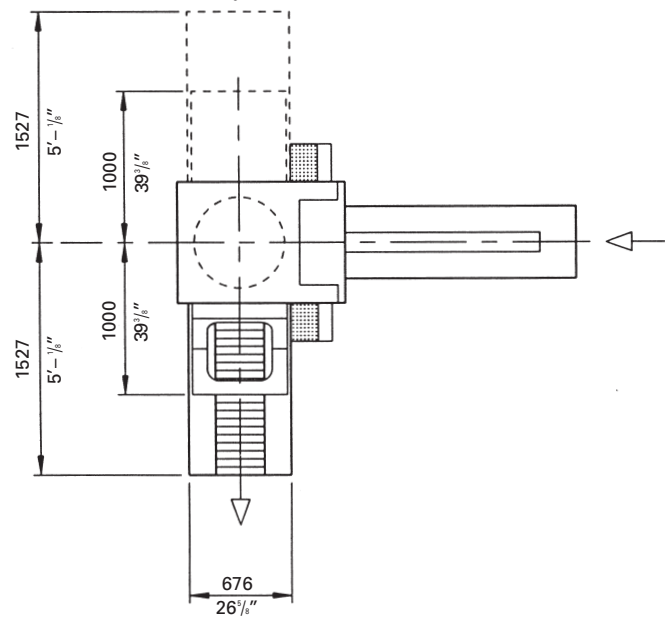

Additional sizes on request.
Design, specifications and
dimensions subject to change.

MÜLLER MARTINI

Müller Martini Marketing AG

Untere Brühlstrasse 13
CH-4800 Zofingen, Switzerland

Phone ++41-62/745 45 75

Fax ++41-62/751 55 50

E-mail info@mullermartini.com

Internet <http://www.mullermartini.com>